

Seattle
International
Film Festival

Volunteer

Handbook

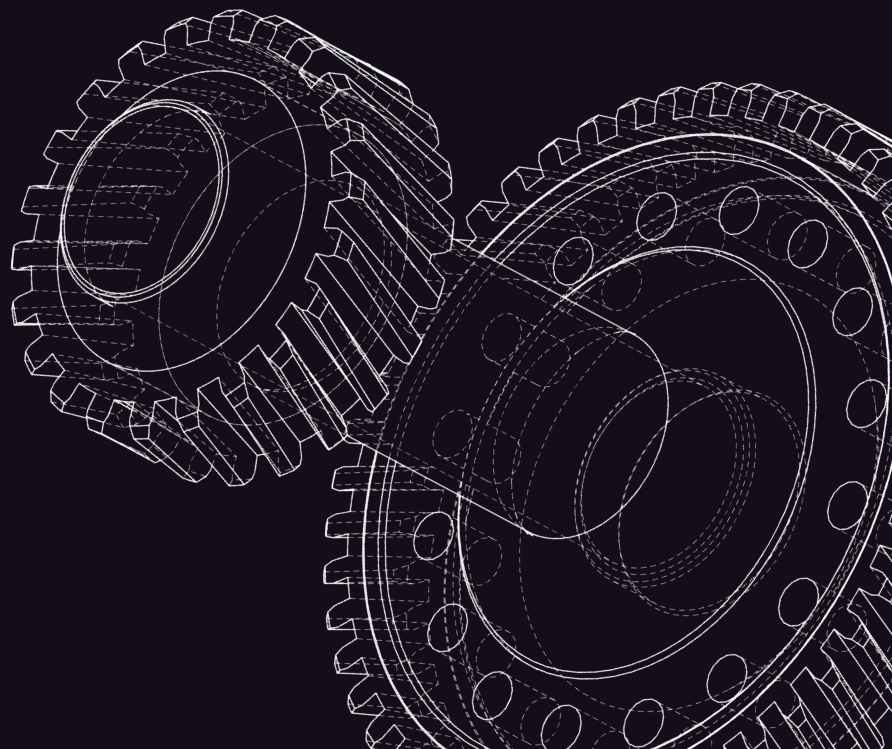



3

Welcome to SIFF

4

Volunteering

5

Registration

6

Expectations + Policies

9

Benefits + Appreciation

11

Getting There

12

Venue Maps

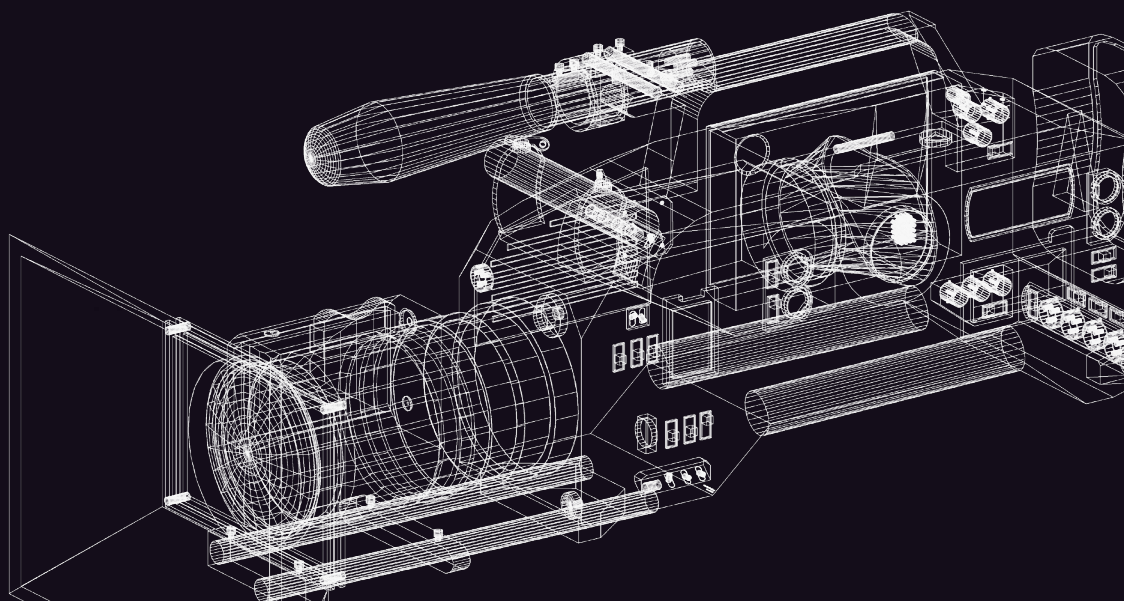



Thank you for joining us at the 52nd Seattle International Film Festival. This year's Festival will run in person May 7-17.

OUR MISSION

SIFF is a 501(c)(3) Seattle-based arts nonprofit dedicated to the creation of vibrant experiences and spaces that champion film discovery and arts education.

OUR VISION

SIFF envisions a thriving arts ecosystem where film discovery encourages a more empathetic, joyful, and connected world.

THE SEATTLE INTERNATIONAL FILM FESTIVAL

SIFF hosts the annual Seattle International Film Festival – traditionally attracting nearly 80,000 attendees to celebrate films from more than 80 countries and regions around the world. Many of the features, short films, and documentaries we screen will not have a return to US cinemas, making it an amazing event to discover new and underrepresented voices and stories.

RACE, EQUITY, & SOCIAL JUSTICE AT SIFF

SIFF is committed to being an anti-racist and anti-oppression organization.

We strive to provide an environment that encourages inclusive experiences for all our audiences, volunteers, artists, staff, and greater community. To create inclusivity and belonging, SIFF expects everyone participating in our events to uphold and embrace this commitment.

We believe that our mission-centered work to create and share space for community bears a responsibility to be fiercely inclusive of communities that have long been systematically marginalized and excluded. We are dedicated to improving racial equity within our organization and our community. Read more at siff.net/equity.

OUR VALUES

At SIFF, we value:

Partnership: We build meaningful relationships with community members and colleagues, working in collaborative ways to create equitable and authentic connections.

Sustainability: We ensure our processes and our outcomes are financially, operationally, and environmentally sustainable in the short and long term. We recognize our impact and that we are part of a greater local and global footprint.

Curiosity: We approach our work with a desire to learn and explore something new. We encourage audiences to learn more about themselves and more about the world.

Inclusion: We create welcoming spaces that are accessible to all where everyone can feel a shared sense of respect and belonging, no matter your story.

Courage: We act with intention, transparency, and accountability in our work. We host films and filmmakers that may not otherwise have a platform.



VOLUNTEER OPPORTUNITIES

The Seattle International Film Festival offers a variety of volunteer opportunities with a flexible time commitment and a buildable schedule that you choose. Festival volunteer teams fall into several categories:

Venue Crew: Be the face of the festival and create a welcoming experience for guests. Roles include ushering, ticket scanning, line management, and getting the theater tidied between screenings.

Admin/Universal: Duties include organizing and inventorying materials, helping with office tasks. This team also helps with one off tasks that help the Festival keep going.

Guest Relations: Offers a range of roles that support the festival's special guests and film teams including guest information services and interpreter services.

Street Team: Community outreach and promotion before the festival. Spread the word and increase visibility for the festival by distributing posters and programs to neighbors.

House Coordinator: If you are looking for a more specialized role in a theater, you can apply for this leadership role, where you oversee Venue Crew volunteers, and support the house manager with screenings related tasks.

Special Events: This application only team follows a pre-set schedule during the Festival and provides front-of-house service for events, including set-up and teardown, guest check-in, bartending, and serving/bussing.

VOLUNTEER GIFT MATCHING

Many companies offer monetary contributions to registered 501(c)(3) non-profit organizations where their employees volunteer. These employer contributions are known by a few different names including volunteer grant programs, employee gift matching, and dollars for doers. Ask your human resources department if your employer offers a volunteer matching program. You can also use [SIFF's corporate giving database](#) to determine if your employer will match volunteer hours and any guidelines. If they do, simply complete and submit the appropriate forms from your employer. Once approved SIFF will receive a direct donation thanks to your hard work!

SIFF is a registered 501(c)(3) non-profit organization, tax ID 91-1489660





If you are a new SIFF Volunteer, please register with **Shiftboard**, our online scheduler where we communicate with our volunteers.

REGISTERING WITH SHIFTBOARD

1. Go to shiftboard.com/siff
2. Review the handbook linked on the registration page, then complete and submit your information.
3. Once approved, you will receive a welcome email.

VOLUNTEER TEAMS

Volunteer shifts are assigned to specific teams on Shiftboard, and you can sign up for available shifts assigned to your teams. All SIFF volunteers are part of "SIFF Universal Team" and "SIFF Cinema Volunteers" automatically.

Assigned Teams

To view your assigned teams, select the **Teams** tab on your dashboard and select the **Worker** tab.

Join Additional Teams

From the Teams tab, select **Join**. Click on a specific team to learn more about the volunteer roles within this team. Depending on the team requirements, you'll either be automatically added as a member, or the Team Manager will need to approve your request.

Seasonal Teams

For the annual Seattle International Film Festival, there will be festival-specific teams that will become available to join. .

SIGNING UP FOR SHIFTS

Signing up for volunteer shifts at SIFF is easy!

1. Select the **Schedules** tab on the main navigation bar.
2. Select an available shift to review the time, location, and shift description. Note: shifts will show only if they are open.
3. Select the blue **Take Shift** button on the right. Confirm your selection.
4. You will receive a confirmation email and be able to view the assigned green shift confirmed on your schedule.

REPORTING FOR YOUR SHIFT

Please arrive at your assigned volunteer location with enough time to be ready at the start of your assigned shift. You will likely be relieving another volunteer, so your punctuality is appreciated. Ensure to check in with your shift lead when you arrive. If you will be delayed, you must notify the Volunteer Manager at volunteers@siff.net as soon as possible.

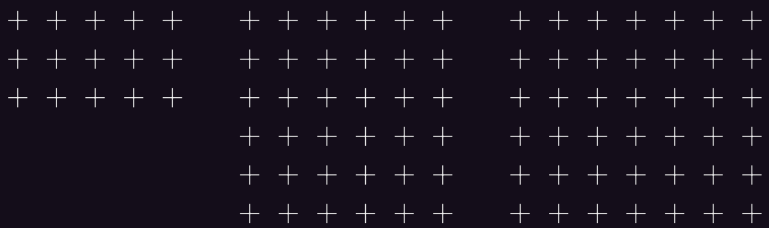

CANCELLATIONS

Volunteers unable to make their shift can unassign their shift via Shiftboard as soon as they know they cannot work it. How to cancel a shift on Shiftboard:

1. Select the shift you need to cancel from your schedules tab.
2. Select the gray **Unassign** button from the menu on the right.
3. Confirm your selection to remove the shift from your schedule.

Calling Out

If "Unassign" is not a selectable option in the shift details, then it is too close to the start time of the shift, and the shift cannot be canceled online. Email volunteers@siff.net to cancel, indicating "Shift Cancellation" in the subject line. Provide the date, time, and location of the shift.

No-Shows

If you fail to let us know you can't make your assigned shift, you will be considered a no-show. When a no-show is reported, your Shiftboard account will be placed on hold, and any future shifts you have scheduled will be unassigned. Your return to work will be at the discretion of SIFF.

SHIFTBOARD SUPPORT

If you need help with Shiftboard, visit support.shiftboard.com/1/en

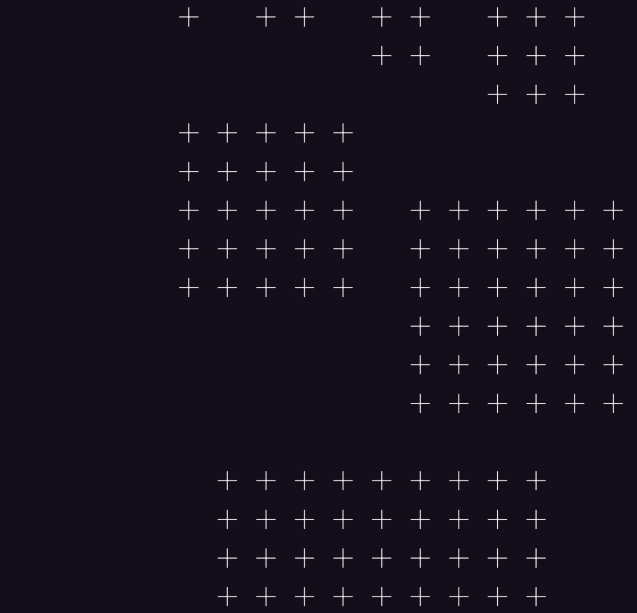
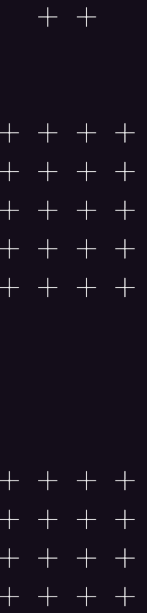
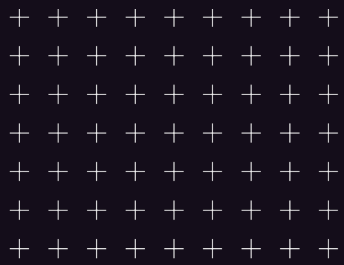
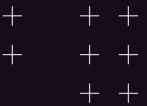



See our [volunteer page](#) for additional information.

Age Policy

Volunteers must be 18 years or older to participate in SIFF's volunteer program.

Attire

Please wear comfortable closed toed shoes, as many positions require standing for long periods. If specific guidance around attire is required, it will be listed in the shift description. If working the SIFF Annual Festival, badges are required to be worn at all times.

Customer Service

While volunteering with SIFF, *you represent the Seattle International Film Festival*. It is important to be pleasant and accommodating. We aim to give patrons a positive and enjoyable experience, and as a volunteer, your goal is to make our guests feel welcome. If you find yourself unsure on how to aid a patron, politely refer them to the nearest SIFF staff member. If no staff members are available, assist the patron as best you can. If their question needs follow-up, take down their contact information and question, and pass it along to a SIFF staff member.

Personal Belongings

Please pack light as there may not be space to store items at your shift location. SIFF is not responsible for any lost or damaged personal items.

Cell Phones and Personal Devices

Cell phones and other devices are not permitted to be used during your volunteer shift. If you need to make or take a call, please discuss with your volunteer coordinator, shift lead, or manager on-site.

Meals

While we occasionally provide treats, SIFF does not provide volunteer shift meals. You are encouraged to eat before your shift. Eating is only permitted in designated areas, during your scheduled breaks.

Concessions

When volunteering in a cinema, SIFF volunteers can enjoy popcorn, soft drinks, coffee, and tea from the concession area. Please introduce yourself and let staff know that you're an on-shift SIFF volunteer before ordering. Food and non-alcoholic beverages can be enjoyed during slow times, as the film screening schedule permits.

Event Catering

Often SIFF provides catering to guests at events. SIFF volunteers are not permitted to eat catering and should not expect to do so while on shift. In some cases, they may be given permission by their supervisor.

Breaks

Breaks based on the length of your shift and must be planned with your onsite coordinator.

Film Viewing

We encourage volunteers to take advantage of their vouchers and see as many films as possible! Volunteers are not entitled to attend screenings during their scheduled shifts.

Accessibility Accommodations

SIFF is happy to support volunteers to have the accessibility accommodations they need to succeed in their role. Contact us at volunteers@siff.net to start the conversation.

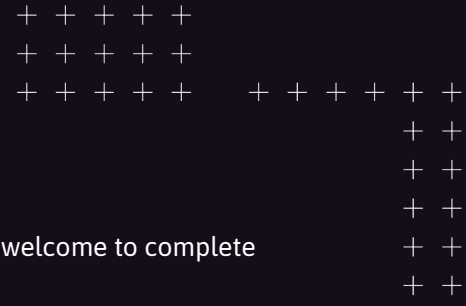

COVID-19 VOLUNTEER POLICY

SIFF has suspended the requirement of volunteers having the COVID vaccine. You are welcome to complete your shifts masked if you prefer.

COMMUNITY AGREEMENT

Kindness

Kindness is a throughline for all that we do at SIFF. Staff, volunteers, and patrons are doing their best, so please use kindness in all interactions. Every volunteer joins SIFF with different experience, whether it's their first day or 20th year, and deserves to be treated with patience, consideration, and respect. If you are unsure about questions or instructions, ask for clarification and be ready to listen. Constructive feedback is welcome, and we ask that it's shared with your shift supervisor to allow for direct change. SIFF does not tolerate rudeness, arguments, or belittling language towards patrons, volunteers, or staff. This means that we also ask that you provide the utmost respect and follow these guidelines in your interactions with and treatment of staff. Here's some examples of what this looks like:

- A lead or member of cinema management may give you instructions that differ from previous instructions or structure seen over years of volunteering. You are welcome to ask questions of leaders and staff around those instructions, but please do not contradict this guidance because "the other way works better."
- Please follow all employee and facility policies.
 - Do not bring in outside food and drink, for example. Whatever we enforce for staff and our audiences should be followed by volunteers. Avoid putting staff in a difficult place of needing to enforce policies with you. Volunteering does not grant you special treatment or waive any rules or policies.
 - If you would like a copy of the employee handbook, please place a request at HR@siff.net
 - Please listen to leadership instructions and follow them regardless of what has been done before.
- A new employee or leader may be learning their way around SIFF and its programs. Please be patient and kind to all staff at all levels, and do not treat staff differently based on their age, tenure, gender or other protected characteristics.
- An employee may be following instructions given to them by their manager. Please do not ask the employee to change or divert from these instructions. You are welcome to speak to the manager to seek more info, but it is up to the manager to decide the best path forward. Do not put pressure on the employee to do something their manager has not asked them to do.

Failure to adhere to this and other policies will result in the following disciplinary procedures and the reconsideration of your participation in the volunteer program.

Anti-Harassment Policy

SIFF is dedicated to providing a harassment-free experience for EVERYONE, regardless of gender, gender identity & expression, age, sexual orientation, disability, physical appearance, body size, race, ethnicity, or religion. SIFF does not tolerate harassment in any form, including at any of our online events or in chat rooms or forums. Harassment includes but is not limited to:

- Offensive comments related to gender, gender identity & expression, age, sexual orientation, disability, physical appearance, body size, race, ethnicity, religion
- Sexual images in public spaces



- Deliberate intimidation, stalking, following, harassing, unwelcomed photography, or recording
- Sustained disruption of programs
- Inappropriate physical contact
- Unwelcome sexual attention

If you are being harassed, notice that someone else is being harassed, or have any other concerns, please contact SIFF staff IMMEDIATELY or contact volunteers@siff.net.

SIFF POLICIES

Media

The Artistic Director or their designees are the sole spokespersons for SIFF. All press inquiries should be directed towards press@siff.net or a member of staff who will relay them to the Press Team.

Confidentiality

The nature of services provided by SIFF requires that information be handled in a private, confidential manner. Information about our business, our employees, or clients — including, but not limited to, film sources and contacts, guest attendance and itinerary information. Festival sales numbers will not be released to people or agencies outside the company without SIFF's written consent. The only exceptions to this policy will be to follow legal or regulatory guidelines. Employees and volunteers are expected to keep such information confidential and not disclose such information to any third party without prior authorization from their supervisor.

Guest Confidentiality Policy

Forward all guest-related questions (who will be attending, etc.) to Press and Public Relations in the Marketing and Communications Department by emailing press@siff.net. Be always pleasant and respectful of guests' privacy, including events. **DO NOT APPROACH GUESTS FOR AUTOGRAPHS OR PHOTOGRAPHS, OR TO DISCUSS PERSONAL PROJECTS. Approaching guests shall be grounds for dismissal.**

Alcohol, Tobacco, and Drug Use

The use of alcohol or any drug that is illegal under either federal or state law (including marijuana) may be a serious threat to personal health, workplace safety, and job performance. Volunteers are strictly prohibited from possessing, selling, consuming, or being under any influence of alcohol or drugs while on the job or in any other manner that may affect the volunteer's work performance or SIFF's interests or reputation. This prohibition also extends to legal drugs for which a volunteer may not have a valid prescription or that are not used in a manner consistent with accepted frequency or dosage requirements.

Volunteers are strictly prohibited from possessing, selling, consuming, or being under the influence of alcohol or illegal drugs (and legal drugs that are not used in a manner consistent with accepted frequency or dosage requirements) while on the job. SIFF is a tobacco-free environment. Please do not consume alcohol, drugs, or tobacco while wearing SIFF volunteer gear. Alcohol served at SIFF events is not for SIFF volunteer consumption while on shift.

Violations of this policy will result in removal from the program.

VOUCHERS TO MEMBERSHIP

In addition to redeeming vouchers for tickets, volunteers may redeem six volunteer vouchers for a SIFF Membership! A SIFF Membership grants you discounts on tickets and passes, reciprocal benefits at several local organizations, and invitations to member-only events and screenings. You can fill out the Vouchers for [Membership Form](#), and learn more about the benefits of a SIFF membership on our Membership page.

VOUCHERS FOR PASS REDEMPTION

Whether you volunteer year round, or during the Festival, SIFF volunteers can redeem unexpired vouchers for passes to enjoy SIFF programming even more!

- 20 volunteer vouchers can be redeemed for a Downtown Annual Pass.
- 30 volunteer vouchers can be redeemed for a 2026 Film Pass (May 7-17, 2026)
- 40 volunteer vouchers can be redeemed for an Ultimate Annual Pass.

Redemption must be completed in person at any SIFF cinema. If you have questions about exchanging vouchers for passes, please contact boxoffice@siff.net.

VOLUNTEER SWAG

Volunteers receive a Festival t-shirt and badge to wear on shift. On top of vouchers, volunteers who meet service hour milestones may earn additional swag, depending on availability.

POPCORN & BEVERAGES

When volunteering in a cinema, you can enjoy popcorn and soft drinks from the concession area. Please introduce yourself and let staff know that you're an on-shift SIFF volunteer before ordering. Food and beverages can be enjoyed during slow times, as the film screening schedule permits.

VOLUNTEER SCREENINGS

Volunteers in good standing with shifts confirmed within the calendar year will be invited to exclusive Volunteer Screenings of SIFF-curated films throughout the year, and may also receive invites to screenings held by partnering agencies.

VOLUNTEER APPRECIATION

The SIFF 2026 Volunteer Appreciation party is scheduled for **May 20, 2026**. Volunteers gather to reflect on a great festival, celebrate volunteer award winners, and enjoy a screening of a 2026 SIFF selection chosen by SIFF Artistic Director Beth Barrett.

VOLUNTEER AWARDS

Presented at the Volunteer Appreciation Event for outstanding service to SIFF:

- **Eric Sorlien Award** is given in recognition of excellent service exceeding all expectations for the Festival.
- **Mark Morey Hours of Service Award** is presented to the volunteer who contributes the greatest number of hours to the Festival.
- **SIFF Shout-Outs** are public declarations of personal praise from Festival team leaders.



The festival will bring increased traffic to the surrounding areas, and public transit is encouraged. Please view parking resources after this table.

King County Metro Trip Planner (tripplanner.kingcounty.gov) and One Bus Away are useful resources to plan ahead.

BIKING

There are bike racks in front of the SIFF Cinema Uptown and throughout the Seattle Center Campus as well as safe bike lockers inside the 1st Ave N Garage, accessible using a BikeLink Card or app.

PARKING RESOURCE

If you do decide to drive, please be advised that SIFF does not reimburse parking expenses.

- Parkopedia, map of lots, street parking, and private garages: parkopedia.com/parking/seattle
- Seattle Department of Transportation, general parking info: seattle.gov/transportation/parking
- Spothero, reservable lot parking: spothero.com/parking
- Parkme, reservable lot parking: parkme.com/seattle-parking

PUBLIC TRANSIT

Paramount Theatre

Major transit hub (multiple routes in 3 block radius) / Link Light Rail: Westlake Station

SIFF Cinema Uptown

Bus Routes: 1, 2, 4, 5, 8, 13, 24, 29, 31, 32, 33 and D Line

SIFF Cinema Downtown

Bus Routes: 1, 2, 3, 4, 5, 13, 14, 17, 21, 24, 28, 33, 40, 62, 124, 131, 132, 994, C Line, D Line, E Line, and H Line) / Link Light Rail: Westlake Station / Monorail / Seattle Streetcar: South Lake Union line

SIFF Film Center + PACCAR IMAX Theater at Pacific Science Center

Bus Routes: 1, 2, 4, 5, 8, 13, 24, 29, 31, 32, 33 and D Line / Monorail



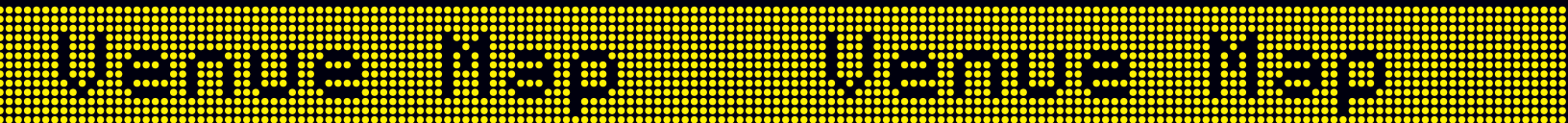

VENUES

Get individual venue details, including accessibility and parking tips at siff.net/festvenues.

- 1 SIFF Cinema Uptown**
511 Queen Anne Ave N
206.464.5830
- 2 SIFF Film Center**
167 Republican Street
206.464.5830
- 3 SIFF Cinema Downtown**
2100 4th Ave
206.464.5830
- 4 PACCAR IMAX Theater at Pacific Science Center**
200 Sue Bird Ct
206.443.2001
- 0 Opening Night Paramount Theatre**
911 Pine St | 206.682.1414
Cannonball Arts
1930 3rd Ave | 206.970.0007

STAY CONNECTED

For schedule changes, daily updates, announcements, and more, sign up for SIFF's enews at siff.net/enews. Follow us on socials @siffnews and be sure to tag us to share your experience!

@siffnews

FEST MERCH

Pick up your Festival swag at Opening Night at the Paramount Theatre, or throughout the Festival at SIFF Cinema Downtown.

Grand Sponsors + Official Hotel

INGENIUXX

WONGDOODY

An Infosys company

GRAND | HYATT®

SEATTLE

Marquee Sponsors

ARTSFUND



CULTURE

Premier Partners



Hong Kong Economic & Trade Office
San Francisco

Blackmagicdesign



Media Partners



the Stranger

The Seattle Times



Community + In-Kind Partners



CANNONBALL
ARTS



FIRST SIGHT PRODUCTIONS
Don't Blink.
FIRSTSIGHTPRODUCTIONS.COM



seattlecenter

IDLEWILD
UNION

PACIFIC
SCIENCE
CENTER

